



PLASTIC OMNIUM

INFINITE INNOVATION

# NAIAS DETROIT 2018



---

## CONTACTS

**Adeline Mickeler** +33 (0)1 40 87 64 00  
amickeler@plasticomnium.com

**Tarick Dali** +33 (0)1 40 70 11 89  
tdali@dgm-conseil.fr

---



# INNOVATION: A PROACTIVE STRATEGY

The revolution in automobiles is changing mobility habits and the energy sources used for propulsion. Also, regulations are becoming tougher and increasingly restrictive. For all these reasons, Plastic Omnium, the world leader in automotive exterior products, fuel tanks and pollution reduction systems, has made innovation central to its strategy for the past 70 years. The results are compelling: Plastic Omnium manages a 4,000-strong patent portfolio and in 2016 was ranked 25th in France for the number of patents filed\*.

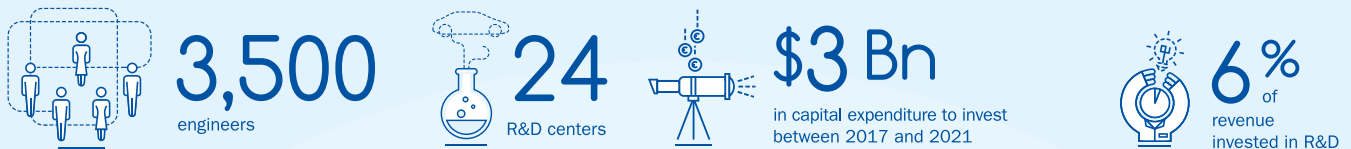

To boost its proactive R&D strategy,  
Plastic Omnium enriched its Openlab ecosystem.

### Advisory committee strengthened

Plastic Omnium set up an Automotive Strategic Advisory Committee to boost its innovation capacity.

Committee members are globally recognized independent experts, including the three latest recruits:

- Prof. Mathias Fink, an expert in wave propagation
- Prof. Emeritus Jay Lee, an expert in predictive data analysis
- Prof. Hiroaki Kitano, an expert in artificial intelligence.

### Investment in diversified entrepreneurship

Plastic Omnium linked up with Israel's Elbit Systems to create EPO-Celltech, a startup specializing in fuel cells and supercapacitors.

Plastic Omnium also co-sponsors the Aster Capital venture capital fund, which invests in startups that develop solutions in new energy sources, connected mobility and innovative materials.

### Close-knit university partnerships

Plastic Omnium has numerous partnerships, notably with:

- The Massachusetts Institute of Technology (MIT)
- Technion, the Israel Institute of Technology
- The Technical University of Denmark (DTU)

Plastic Omnium is also a member of the Hydrogen Council launched by leading multinationals.

### Innovation challenges

In its Open Innovation research, Plastic Omnium explores new ways of stimulating innovation, both in-house and outside the company:

- The PO Innovation Award: stimulating and recognizing innovations proposed by employees, whatever their job in the company.
- Hackathon
- Crowdsourcing



\*Source : INPI April 2017



# Tomorrow's clean, connected car

Environmental standards are undergoing constant change. At Plastic Omnium, we take these standards into account to invent tomorrow's vehicle, embedding innovations in a sustainable development approach. Our goal is to offer automakers cutting-edge equipment and solutions that will bring to life tomorrow's clean, connected car.

## Stricter environmental requirements

### Lighter vehicles

Making vehicles lighter reduces their CO<sub>2</sub> emissions. Plastic Omnium "lightweights" its exterior products by using plastic components and modules that are 30% lighter than metal while offering excellent mechanical performance and robustness. Plastic Omnium's technologies lighten vehicles by up to 200 kg, which translates into 20 g less CO<sub>2</sub> per kilometer.

Reducing component weight is also vital for hybrid and electric vehicles as it increases their driving range and compensates for the battery weight.

Plastic Omnium's expert engineers also offer automakers solutions to optimize passive and active aerodynamics, further reducing CO<sub>2</sub> emissions by over 4 g/km.

### The energy mix revolution

Plastic Omnium is the leader in energy storage systems, whether for standard gasoline and diesel vehicles as well as hybrids. Standard engines remain in the majority in 2017, but by 2030 almost 45% of new vehicles will have hybrid powertrains, compared

with 6% in 2017. Continuous improvement programs are active for current storage systems, and Plastic Omnium is also working on alternative energy solutions such as hydrogen storage, fuel cells and supercapacitors.

## More connected than ever

The market for connected cars is on the increase. According to a study by PwC\*, between 2015 and 2020 the market is set to quadruple to €115 billion in revenue, to the benefit of two priority segments: safety (€47 billion) and assisted driving (€35 billion).

Plastic Omnium's development strategy is staying ahead of market changes. Plastic Omnium bumpers currently include up to 50 high-tech components that augment driver intelligence and make driving easier and safer.

Plastic Omnium is contributing to tomorrow's intelligent car thanks to its expertise in function integration, backed by the outstanding electromagnetic transparency performance of plastics. The company's exterior components will incorporate a large number of radars and other sensors that will offer even greater styling flexibility on top of protective features.

\*Source: Strategy& PwC study "Connected Car report 2016"



OVER \$2 Bn\*  
revenue

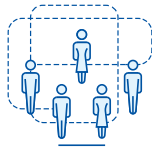

5,000  
employee including  
668 engineers

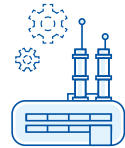

19  
Plants  
6 R&D centers



2.5 M\*  
Bumpers



5.7 M\*  
Fuel systems



0.6 M\*  
SCR systems

12 charitable organizations supported by Plastic Omnium including Focus HOPE

Plastic Omnium's partnership with Focus Hope demonstrates our commitment to creating opportunities for the next generation. Our contribution to date is more than **\$1.5 million.**



**Focus: HOPE**  
Celebrating Diversity Since 1968

University partnership

- MIT ( Massachusetts Institute of Technology)
- Kettering University



Massachusetts  
Institute of  
Technology



# OUR PRESENCE IN NORTH AMERICA

Since its entry into the US automotive market in 1994, Plastic Omnium has become a major player in North America and developed strong relationships with its OEM customers such as BMW, Ford, Volkswagen and General Motors. The Plastic Omnium teams have been recognized many times over the years for their commitment and performance.



●  
Fairfax

## Greer: a 4.0 plant

**SOP: 11/18**

Plastic Omnium is currently building its first “industry 4.0” plant in Greer, South Carolina. This flagship facility will be the largest in the group’s history. Employing new manufacturing techniques, the plant will also meet market needs for mass customization of variants and models, while offering best in class operational performance.

Smyrna  
**SOP 08/18**

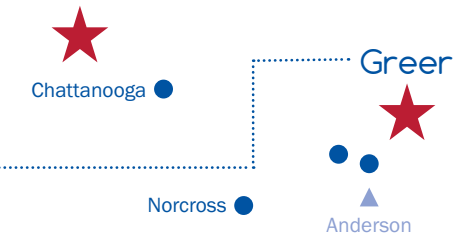

500 people | 60,000m<sup>2</sup> | Customer: BMW

CSR: • Waterborne solution • Paintline • Led Lighting

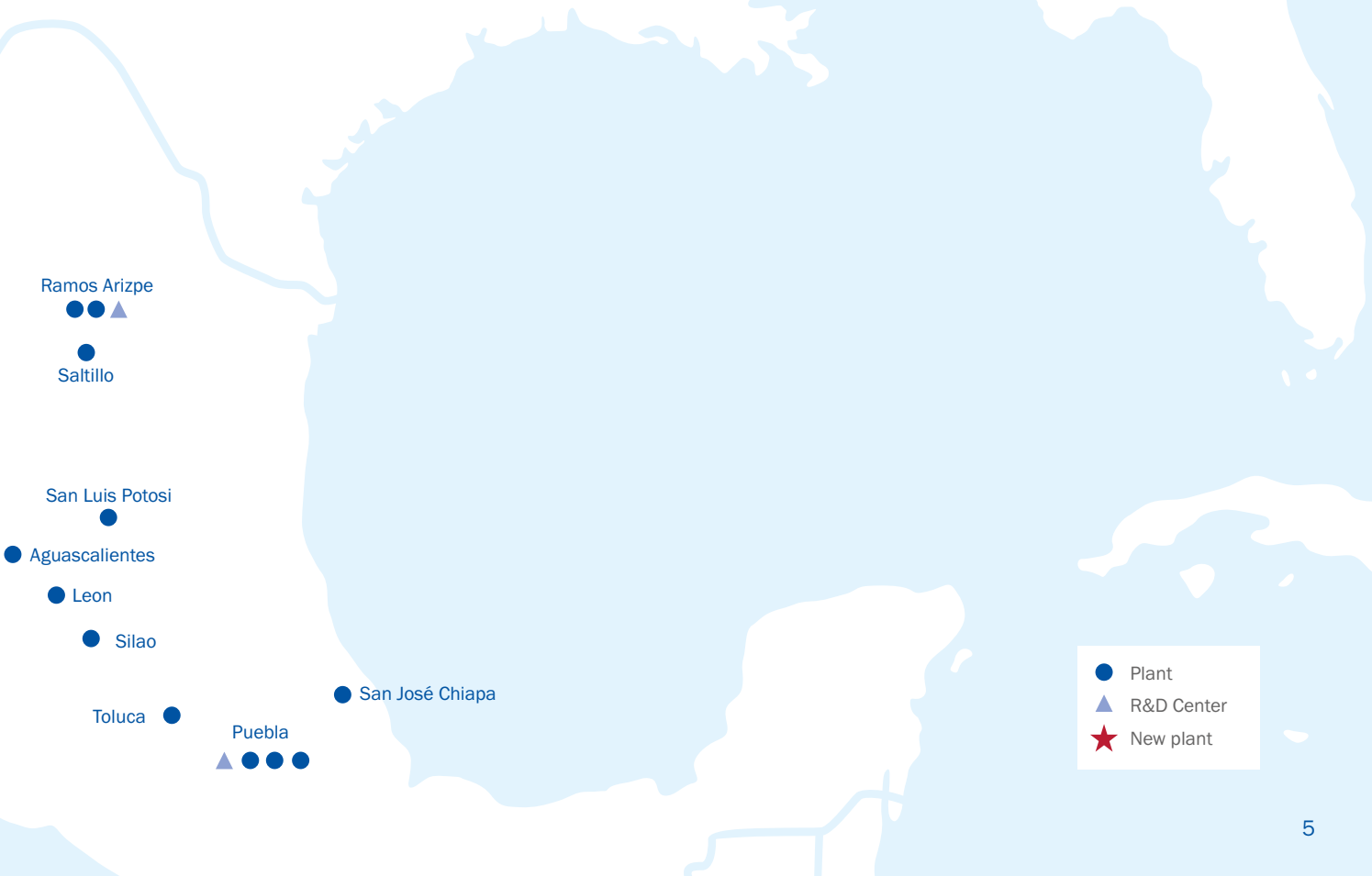

- Plant
- ▲ R&D Center
- ★ New plant

# PLASTIC OMNIUM INNOVATIONS:

## Intelligent bumper

### Integrated radar

Plastic Omnium has developed intelligent bumpers that include optimally mounted radars. Radars are fully integrated into the bumpers and provide first-class performance thanks to electromagnetic-wave permeable plastics.

Integrated radar for enhanced styling.

### Impact detection and absorption system

The engineering procedure for bumpers patented by Plastic Omnium offers an impact absorption module that incorporates a host of functions ranging from innovative detection systems to improved impact management. The bumper also includes an active aerodynamic system. The new bumper module replaces seven separate components; it is also lighter, reducing CO<sub>2</sub> emissions.

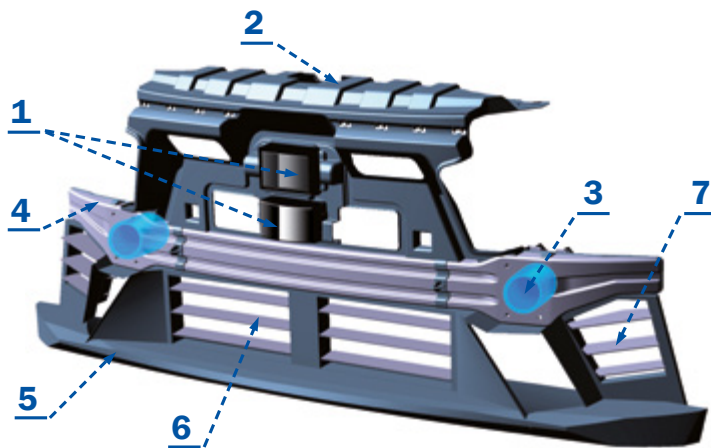

- 1. Lidar and radar adaptive cruise control (ACC)
- 2. Bumper reinforcement
- 3. Crash box in high-performance composites
- 4. Shock absorption beam
- 5. Pedestrian safety system
- 6. Active air-flow management for engine cooling
- 7. Active flow management for air exchangers

5 kg lighter,  
reducing CO<sub>2</sub>  
by 0.5 g per km.

More  
aerodynamic,  
reducing CO<sub>2</sub>  
by an extra 2 g per km.

### Innovative front grille

Plastic Omnium has developed a manufacturing process that incorporates modern radar technologies in an innovative, three-function front grille:

A chrome finish compatible with radars  
(previously impossible).

De-icing system  
to ensure the grille works  
in all weathers.

An integrated  
lighting system  
based on flexible optical fibers.





# A lighter, more reactive tailgate

The new-generation tailgate is made from high-performance composites that reduce weight by around **30%** compared with steel. Thanks to the light plastic materials, many new aerodynamic and interactive functions can be integrated.

## Safety and personalization

The tailgate can display messages to “talk” to its surroundings. Many different messages can be displayed on a transparent area that also serves to display the driver’s own personalized messages.



## An interactive tailgate

Solutions have been developed that enable the tailgate to interact in three ways:

- The facial recognition system uses a specific software program to open the vehicle
- The “touch and open” and “touch and stop” systems work through conductive paint
- The obstacle avoidance system for ground level or higher levels avoids damage when opening the trunk.

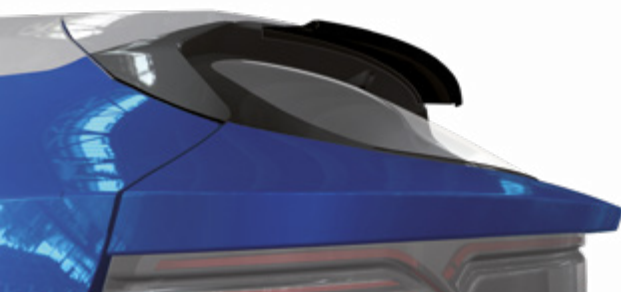

**CO<sub>2</sub> emissions reduced**  
by as much as 2 g per km.

## A more aerodynamic tailgate

Tailgate aerodynamics are improved by an active rear spoiler and a side spoiler that direct the air better over the car roof. The drag coefficient is improved by 3-4%, reducing CO<sub>2</sub> emissions by 1 g per km.

In addition, a mobile diffuser in the rear bumper spreads out under the floor to improve the drag coefficient by a further 3% and reduce CO<sub>2</sub> emissions by 1 g per km.



## Cleaner energy

Plastic Omnium is the global leader in low emission fuel and exhaust treatment systems, equipping one in every four vehicles produced worldwide. As environmental standards become increasingly strict, Plastic Omnium helps automakers reduce emissions.

## Solution for hybrid motor

Plastic Omnium offers solutions for plug-in hybrids.

The INWIN fuel system's optimal architecture withstands increased gasoline vapor pressure when the vehicle is running on electricity.



TANKTRONIC®'s innovative, simplified architecture includes an E-valve with an electronic control device. The system improves operation at low cost.

---

### 64 PATENTS

filed by Plastic Omnium for the INWIN and TANKTRONIC® solutions.



# PLASTIC OMNIUM INNOVATIONS:

## Water injection system

Plastic Omnium has developed a technology that can be adapted for all gasoline vehicles. First designed to improve engine performance, the water injection system significantly reduces fuel consumption, which in turn reduces CO<sub>2</sub> emissions.

CO<sub>2</sub> emissions reduced by up to 15%.

A cost-effective solution.



## Clean diesel: the SCR\*

SCR technology has been applied to diesel fueled vehicles since 2008 to treat nitrogen oxide (NOx) emissions in compliance with the strictest regulations.

The technology involves vaporizing AdBlue® into the exhaust which, when it comes into contact with diesel exhaust gases, generates a chemical reaction that transforms polluting nitrogen oxides into harmless nitrogen and water vapor.

\*Selective Catalytic Reduction

SCR solutions reduce NOx emissions by almost 95%.

OVER 172 PATENTS filed by Plastic Omnium for its SCR solutions.

OVER 1 MILLION SCR systems sold by Plastic Omnium in 2017.



## Clean diesel: Dual SCR

Suited for new generations of Diesel engines, our Dual SCR system combines benefits from both AdBlue® and amoniac gaz direct injection to reduce NOx

Improves SCR efficiency during engine start-up and in urban driving conditions.

COMPLIANT WITH EURO7 REGULATIONS

1. Hot engine conditions = **AdBlue® injection**
2. Cold engine conditions = **Amoniac gas injection**

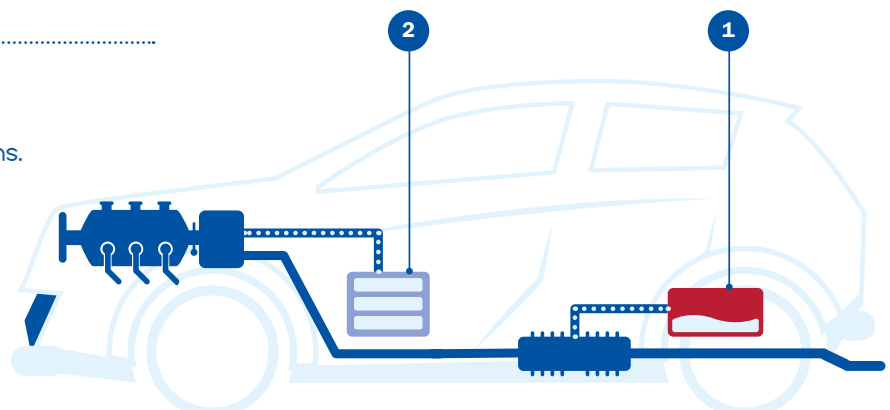

# Hydrogen: Tomorrow's clean fuel?

Plastic Omnium has developed a high-pressure hydrogen storage system.

The hydrogen is stored in type IV\* tanks that can withstand internal stresses.

The tank is made from a thermoplastic sealing liner of around 5-mm and a thick carbon-fiber layer that takes up the mechanical stresses created by internal pressure in the tank.

Plastic Omnium's R&D has been working on a technology for several years that now enables it to present a 700-bar tank.

When fitted with two 60-liter tanks, a vehicle's driving range can be as high as 800 km.

Plastic Omnium recently acquired two companies operating in the field of propulsion by hydrogen fuel cells: Swiss Hydrogen and Optimum CPV. These acquisitions reinforce the positioning of Plastic Omnium as an electric propulsion player.

\*Tanks made of composite materials and plastics



**3 to 4  
minutes:**

the time needed to  
fill a vehicle at a  
hydrogen station.

**800 km:**

the distance traveled on a  
2x 60-liter tank system.

**4 times lighter**

than metal systems thanks to its  
carbon fiber and plastic components.

# Fuel cell system: A zero-emission solution

## From hydrogen to electrical energy

One focus of innovation at Plastic Omnium is to power electric vehicle motors with a fuel cell.

The cell converts oxygen and tank-stored hydrogen into electrical energy to propel the vehicle.

The system discharges nothing other than water and heat.

The solution of a new-generation fuel cell combined with tank-stored hydrogen is much lighter than standard battery solutions and provides a driving range equivalent to today's gasoline or diesel cars.



EPO-CELLTECH

Fuel cells combined with tank-stored hydrogen will free electric vehicles from the problems of limited range and lengthy charging times, as well as their dependence on weather conditions. Such issues are currently holding back electric vehicle development.

In 2016, Plastic Omnium and Elbit Systems, an Israeli company, created EPO-Celltech, a startup specializing in fuel cells and supercapacitors. A joint research center opened in mid-2016 in Caesarea in Israel. Plastic Omnium is contributing its automotive expertise in electronic system and fluid management. Plastic Omnium's know-how is combined with the developments already achieved by Elbit Systems in creating a fuel cell with very low precious-metal content along with a new supercapacitor range.

The research team comprises 50 people based in Belgium and Israel.

**No pollutant emissions:**  
the vehicle emits only water.

**Enhanced energy efficiency**  
compared with internal combustion engines.

**Range unaffected by weather conditions**  
as fuel-cell heat is recovered to heat car cabin.

1. Air enters the vehicle.
2. The air reaches the fuel cell.
3. The hydrogen reacts with the oxygen in the fuel cell.
4. The electricity generated by the fuel cell supplies the motor.
5. The motor propels the vehicle.
6. The vehicle emits nothing other than water.

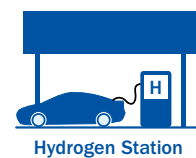
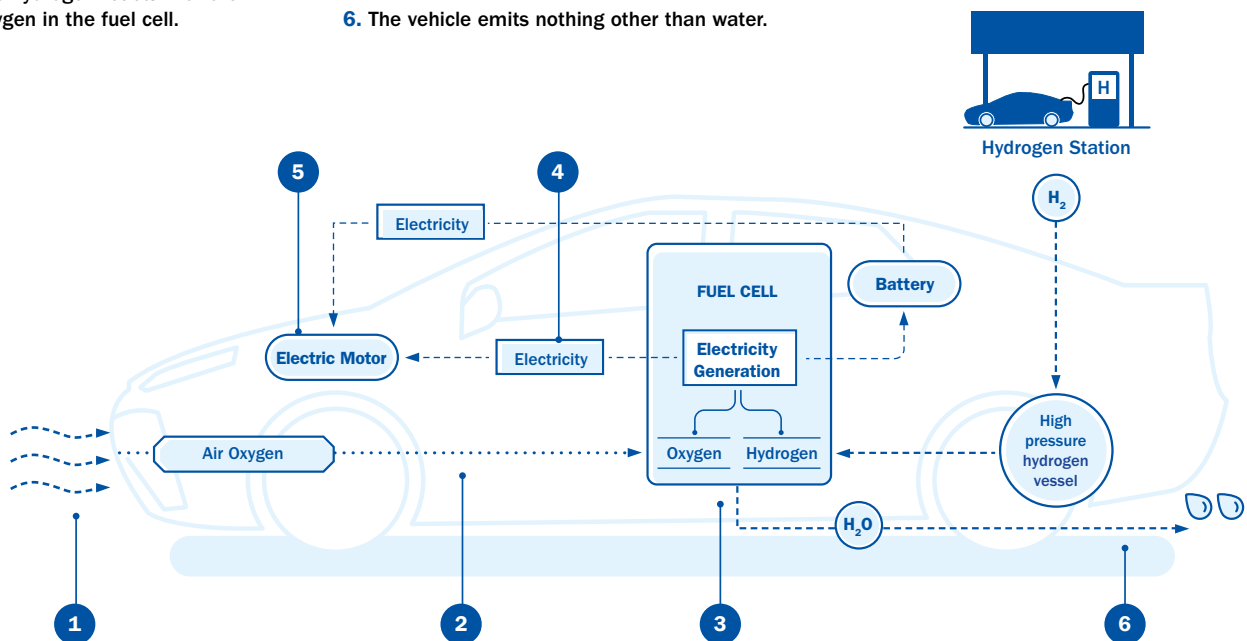

# ABOUT PLASTIC OMNIUM

Through innovation and anticipating market trends, the company has been able to grasp all opportunities on offer throughout its 70-year history.

Plastic Omnium is the world leader in exterior products and modules and fuel systems for automobiles.

## WORLD LEADER IN 2 FIELDS:

### Exterior products

designs, develops and manufactures exterior products and modules in plastic or composite materials; **one vehicle in six produced around the world has parts supplied by Plastic Omnium. 29 million bumpers produced annually.**

### Propulsion

designs, develops and manufactures fuel systems and pollution reduction systems; **one vehicle in four produced around the world has systems supplied by Plastic Omnium. 22 million tank systems produced annually.**

74 automaker customers



128  
production  
plants around  
the world

33 000  
employees

29<sup>th</sup>  
global equipment  
supplier

Revenue of  
~\$9.6 Bn

2710 Bellingham Road, Suite 400  
Michigan, 48083 Troy - **United States**  
Tél. : +1 248 458 07 00  
Fax : +1 866 410 53 19  
[www.plasticomnium.com](http://www.plasticomnium.com)

1, allée Pierre Burelle  
92593 Levallois Cedex - **France**  
Tél. : +33 (0)1 40 87 64 00  
Fax : +33 (0)1 47 39 78 98  
[www.plasticomnium.com](http://www.plasticomnium.com)



INFINITE INNOVATION